



Brand of NTN corporation

Technical data

UC211G2

Insert bearings



Spherical outer diameter, fixing by socket set screw, seal with slinger

VISUAL (S)

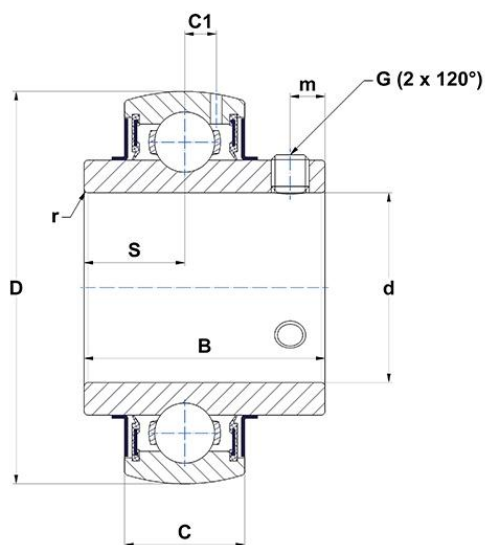

PRODUCT DEFINITION

Brand	SNR
B - Width of Inner Ring	55,6 mm
C - Width of Outer Ring	25 mm
C1 - Distance center of OR to center of lubrication zone	7,2 mm
d - Shaft diameter	55 mm
D - Outer diameter of OR	100 mm
G - Set screw size	M10x1,25
m - Distance to set screw	9 mm



NTN Europe

1 rue des Usines · BP 2017 · 74010 Annecy Cedex · France · Tel. +33 (0)4 50 65 30 00
 S.A. au capital de 322 639 919 € · RCS ANNECY B 325 821 072 · Id. Fiscale : FR 48 325 821 072
 SIRET 325 821 072 00015 · Code APE 2815 Z · Code NACE 28.15

PRODUCT DEFINITION

r - Radius Inner Ring	1.1
S - Distance front side/bearing centre	22,2 mm
f0 - Factor	14.4
SW - Wrench size	5 mm

PRODUCT PERFORMANCE

C - Dynamic load rating	43,55 kN
C0 - Static load rating	29,2 kN
Operating temperature min.	-20 °C
Operating temperature max.	100 °C

OTHER FEATURES

Mass	1,12 kg
Recommended tightening torque for set screw	22 N-m

BEARING FREQUENCIES

BPFO - Over rolling frequency on outer ring (60 rpm)	4.07822580645161 Hz
BPMF - Over rolling frequency on inner (60 rpm)	5.92177419354839 Hz
BSF - Over rolling frequency on rolling element (60 rpm)	5.23996712104535 Hz
BRF - Fréquence de rotation : Élément roulant	2.61998356052267 Hz
FTF - Rotational frequency - cage (60 rpm)	0.407822580645161 Hz

ESHOPDONOTDISPLAY

Image	UC200_1.jpg, UC200_3.jpg
Tracepart	Oui/Yes
Reference	UC211G2
Locking devices	Set screw



Datasheet Type

UC200

